

PATENTED SHALLOW-DIP-TECHNOLOGY + CONTACT HEAT

CND TEPPANYAKI GRILL TABLE SPECIFICATIONS

models/sizes:

TS-35 | 35-1/2" Ø x 28¾" H (90 cm x 73 cm)

TS-47 | 47" Ø x 28¾" H (120 cm x 73 cm)

~346 sq/inch HOT cooking center incl. warming

TS-56 | 56" Ø x 28¾" H (143 cm x 73 cm)

Custom-made to order.

INDOOR + OUTDOOR USE | IPX4 RATED

Material: Professional Food Grade Best Alloy German Stainless Steel type 304 (V2A) 5/32" thick (4 mm) cold pressed, hand-welded. Built-to-last. Elegant silk-brushed finish.

Power: **1800 Watt** | 1.8 kWh on high

Electric: **120V | 50-60 Hz | 15 AMP**

alt. 240V | 50-60 Hz | 8 AMP

ProStyle 2250 Watt | 240V | 10 AMP

Analog infinitely variable temperature control:

1-10 dial | 2 indicator lights | thermostat

Contact Heat: 150°F to 450°F (65° to 230°C)

5 Year ltd. Warranty. Electrical + electronic parts: 1 year limited manufacturers'. CE/ GS/ VDE approved. Electrical + electronic Components: UL approved.



CUSTOM-MADE UPGRADES:-

Type 316 marine grade stainless steel

- 42" bar-height center column (TS-35/47 only)

MADE-TO-ORDER MODEL TS-56:

56 inch Ø x 28¾" H (143 cm x 73 cm)

Hot cooking center ~24"Ø

230V only | 3000 Watt | 3 kWh on 10

Custom sizes on request.

Shipping Weight per skid/ea:

TS-35: 125 lbs (56.7 kg)

TS-47: 210 lbs (95.5 kg)



- 1 COLD DINING AREA
- 2 HOT COOKING CENTER
- 3 POWER CORD RECEPTACLE at rear of control box
- 4 INDICATOR LIGHTS control box



Stainless steel production uses up to 80% recycled raw material



SINCE 1887 - OVER 125 YEARS OF INNOVATION & PRECISION MANUFACTURING



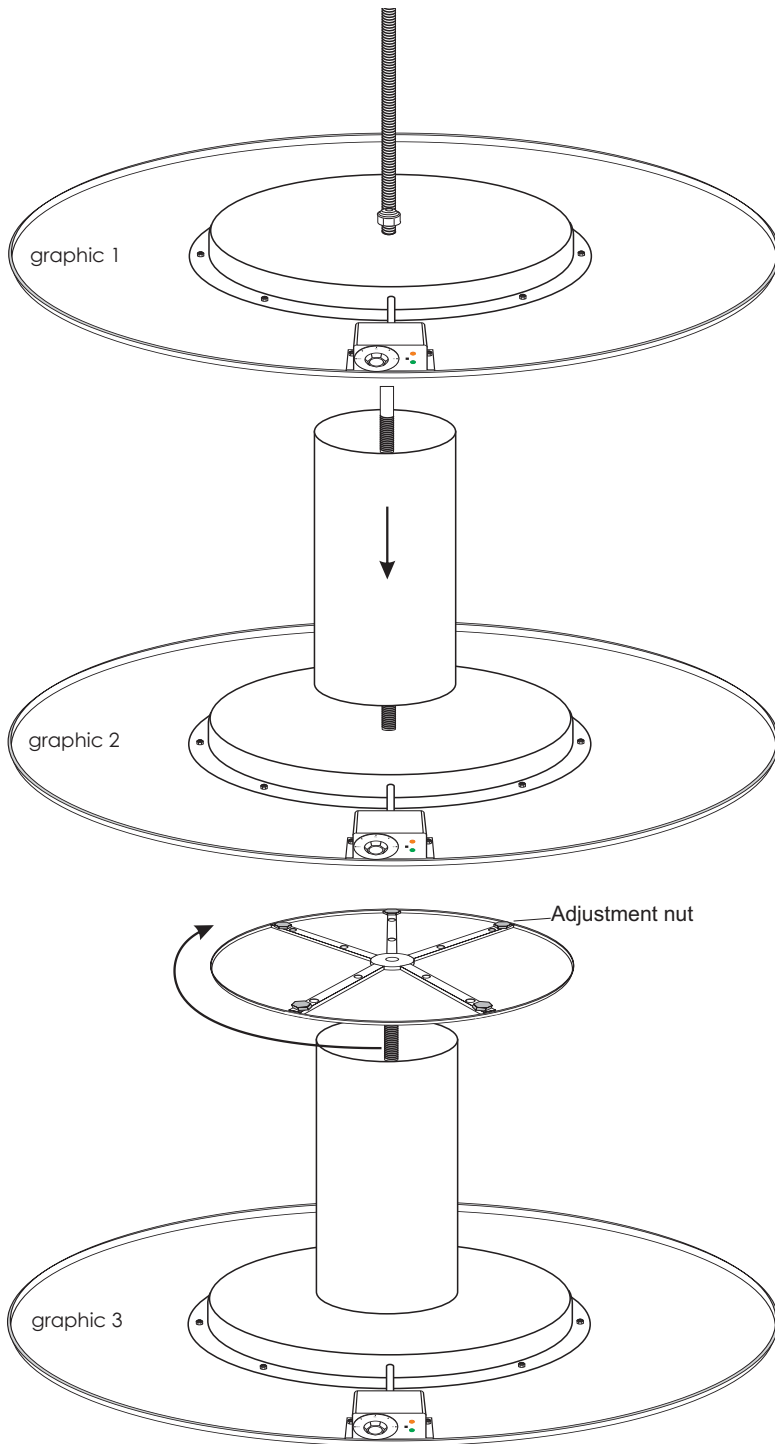

Step 1: Open the box/remove lid. Tabletop is laying bottom up in the box. Remove packaging from threaded rod (packed separately).

Leave tabletop in the box to protect the surface from scratching during assembly.

If provided, place metal plate on top of the heating element enclosure and align the holes. Insert the threaded rod (nut down) into the designated centered hole. Turn the rod clockwise until hand-tight and nut is flush with the heating element. Do not use power tools! (graphic 1).

Step 2: Slide the stand (tube) over the threaded rod, guiding the rod carefully through the designated holes in each inner brackets at either end of the stand/tube. (graphic 2)

Step 3: Turn the pedestal disk upside down, position the designated hole on top of the threaded rod. Turn pedestal clockwise while supporting it with your hands until it is firmly connected with the stand and the top of the table.

Step 4: Turn the now fully assembled table to its upright position and level it by rising or lowering the respective adjustment nuts at the underside of the pedestal disk. Check voltage label. Now connect the power cord to table and then to respective three prong grounded power outlet.

PATENTED SHALLOW-DIP-TECHNOLOGY + CONTACT HEAT

**5 Year Limited
Manufacturer Warranty**

Electrical + electronic parts:
1 year limited manufacturers'.

CE/ GS/ VDE European
Safety Certifications



Electrical + electronic
Components: UL approved.

INDOOR + OUTDOOR IPX4 RATED

Material:
Professional Food Grade Premium
German Stainless Steel type 304
8-10 gauge | 1/8" - 5/32" | 4-5 mm thick
Cold pressed + hand-welded
Silk-brushed Finish.

Power: **1800 Watt** | 1.8 kWh on high
Electric: **120V | 50-60 Hz | 15 AMP**
alt. **240V | 50-60 Hz | 8 AMP**
ProStyle 2250 Watt | 240V | 10 AMP

Contact Heat:
150°F to 430°F (65°-220°C)

Analog Temperature Control:
1-10 dial with thermostat
2 LED control lights
Touch-Sensor Controls
coming soon.

10 ft. POWER CABLE

STANDARD 3-PRONG
GROUNDED PLUG

**BUILT-IN
UNITS:
components 1 - 6 ONLY**

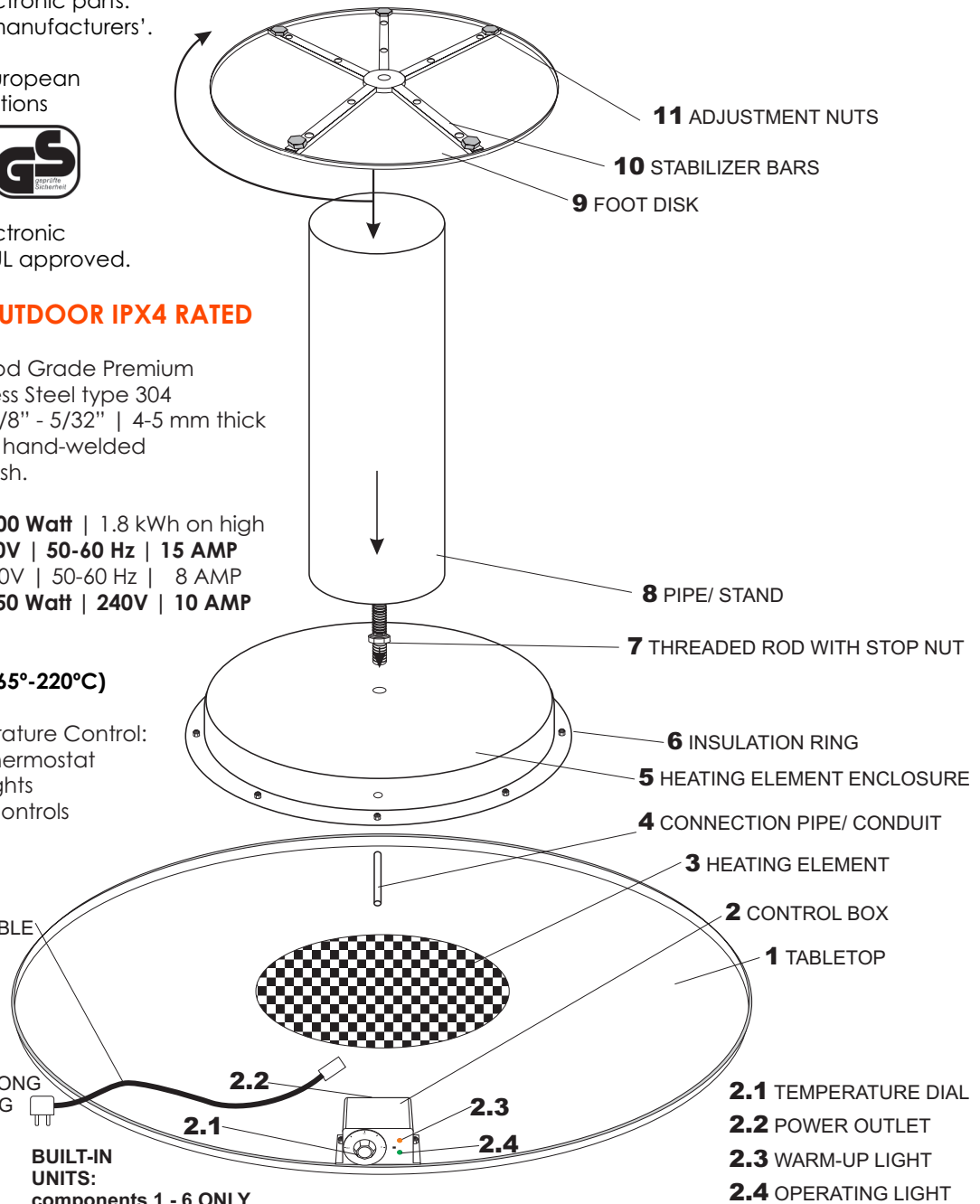

SINCE 1887 - OVER 125 YEARS OF INNOVATION & PRECISION MANUFACTURING

